

ACURA SPA SYSTEMS, INC.

MEGATROL™ SERIES-230

MODEL:	MT60DP2DH5B1S1G	
240V	60A. Service	60 Hz
REVISION:	03/04/07	* Optional Items

WARNING: MUST BE WIRED PER NATIONAL ELECTRIC CODE AND ALL LOCAL CODES AND REGULATIONS.

NOTE: To supply 120V to the heater, move RED wire on load side of **Terminal Block** from RED (L2) to WHITE (N).

NOTE: To supply 120V to the pump, move BLUE wire on load side of **Terminal Block** from RED (L2) to WHITE (N).

Side Connectors

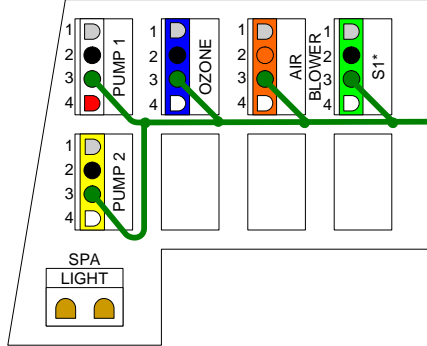

MT60DP2DH5B1S1G	
MT	= Megatrol Series
60	= 60 Amp Service
DP2	= Dual Pumps, 240V
DH5	= Dual Heaters, 2 x 5.5kW
B1	= Blower, 120V
S1	= Receptacle, 120V
G	= G.F.C.I.

Indicator Lights Connections

A	> 120V Power	[L1,N]
B	> 240V Power	[L1,L2]
C	> Low Pump	[4,1]
D	> High Pump	[2,1]
E*	> Pump 2	[4,1]
F*	>	
G*	>	
H*	> Blower	[2,1]
I	> Heater 1	
J*	> Heater 2	

* Optional Items

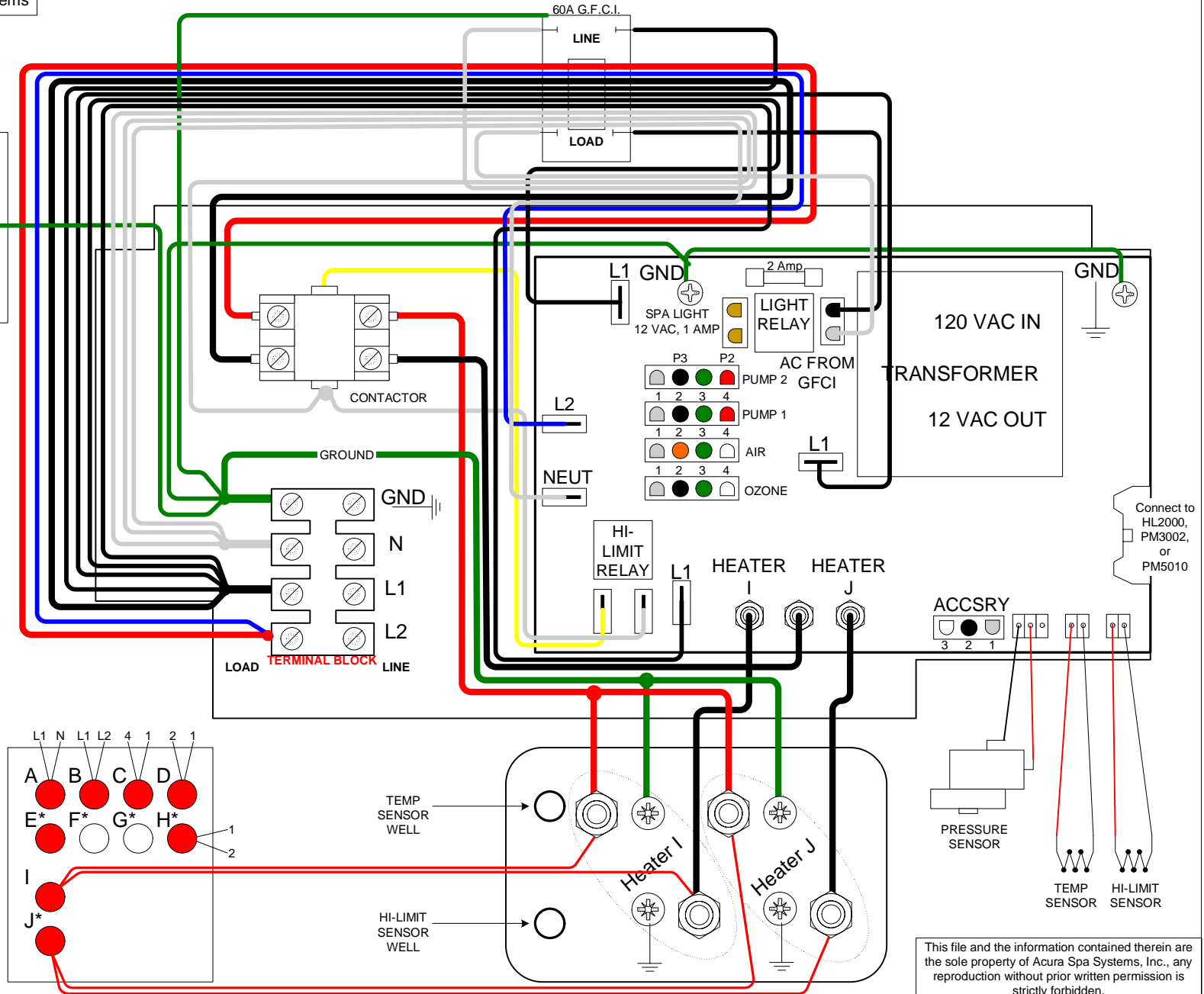

This file and the information contained therein are the sole property of Acura Spa Systems, Inc., any reproduction without prior written permission is strictly forbidden.